

Multi-wavelength TCSPC lifetime imaging

Wolfgang Becker^a, Axel Bergmann^a,

Christoph Biskup^b, Thomas Zimmer^b, Nikolaj Klöcker^c, Klaus Benndorf^b

^aBecker & Hickl GmbH, Nahmitzer Damm 30, D-12277 Berlin, Germany

^bFriedrich-Schiller-Universität, Institut für Physiologie II, Teichgraben 8, D-07740 Jena, Germany

^cEberhard Karls Universität Tübingen, Institut für Physiologie II, D-72074 Tübingen, Germany

ABSTRACT

We present a novel time-correlated single photon counting (TCSPC) imaging technique that allows time-resolved multi-wavelength imaging in conjunction with a laser scanning microscope and a pulsed excitation source. The technique is based on a four-dimensional histogramming process that records the photon density over time, the x-y coordinates of the scanning area and the detector channel number. The histogramming process avoids any time gating or wavelength scanning and therefore yields a near-perfect counting efficiency. Applied to resonance energy transfer (RET) measurements, the setup is capable to record time-resolved fluorescence decays for the donor and the acceptor simultaneously.

1. INTRODUCTION

Since their introduction in the late eighties, laser scanning microscopes have caused a revolution in cell imaging [1]. High contrast fluorescence imaging, depth resolution, and deep tissue imaging are features beyond the reach of conventional microscopes [2]. Recent developments resulted in scanning microscopes that record fluorescence spectra for all pixels of the image and therefore allow efficient discrimination between different fluorescence markers [3]. However, these conventional fluorescence imaging techniques have several limitations which can be overcome by fluorescence lifetime measurements. Time-resolved data provide more information than steady-state data. Only fluorescence lifetime measurements allow to evaluate the underlying mechanism of energy transfer processes such as fluorescence quenching or resonance energy transfer (RET) and provide information upon the fraction of donor molecules participating in RET.

Fluorescence lifetime imaging on the stage of a laser scanning microscope can be accomplished by single-channel modulation techniques, gating or modulating an image intensifier [4,5], gated photon counting [6,7] or time-correlated single photon counting [8]. All these methods can be used with one-photon excitation or two-photon excitation [9,10].

At present, only TCSPC is able to achieve a counting efficiency close to one, a time resolution below 50 ps, and a pixel dwell time below 1 μ s [11,12]. Count rate limitations typical for traditional TCSPC setups have been overcome now [13] and a multi-detector technique has become available [13,14].

2. MICROSCOPE SETUP

The complete setup used in this study consists of a laser scanning microscope (LSM-510, Zeiss), a polychromator (250is, Chromex), and a 16 channel TCSPC detector head (PML-16, Becker & Hickl) connected to a TCSPC imaging module (SPC-730, Becker & Hickl). A scheme of the setup is shown in Fig. 1.

The fibre output option of the LSM-510 scanning head is used to guide the emitted light to the polychromator. The polychromator spreads the incident light along the horizontal axes and focuses it on the PML-16 detector module. The PML-16 detector module has 16 parallel PMT channels in a linear arrangement. For each detected photon, it delivers a timing pulse and a 4 bit number that indicates in which channel the photon was detected [14]. These signals are fed to the SPC-730 TCSPC imaging module [12] and used to determine time and wavelength of the detected photons. The reference signal for the time measurement is obtained from a photodiode on which a part of the laser beam is reflected. The imaging process in the SPC-730 module is synchronised with the scanning process via the frame sync, line sync and pixel sync signal of the laser scanning microscope.

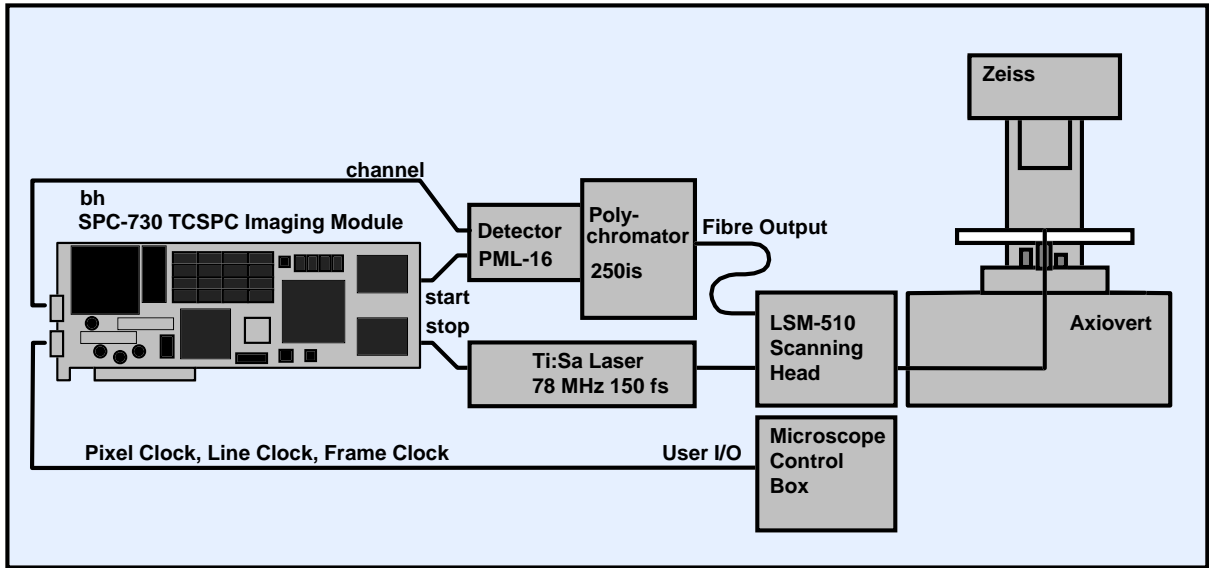

Fig. 1: Setup of the multi-wavelength lifetime microscope

3. MULTICHANNEL TCSPC IMAGING

The principle of the TCSPC imaging technique is shown in fig. 2. The recording electronics consists of a time measurement channel, a scanning interface, a detector channel register, and a large histogram memory.

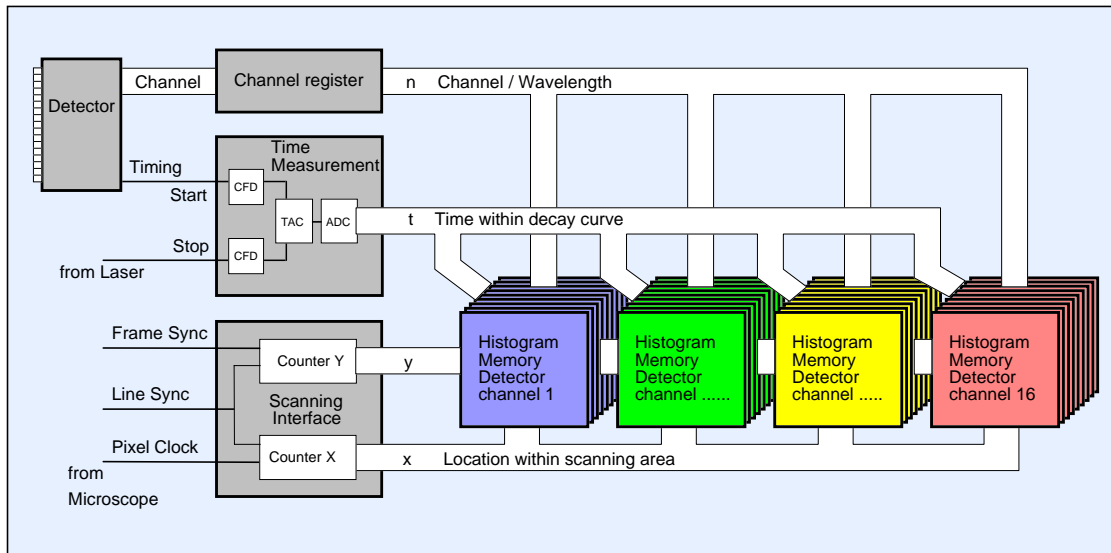

Fig. 2: Multichannel TCSPC imaging

The time measurement channel contains the usual building blocks (CFDs, TAC, ADC) in the 'reversed start-stop' configuration. For each photon, it determines the detection time (t) with respect to the next laser pulse. The scanning interface is a system of counters which receive the scan control signals (frame sync, line sync and pixel clock) from the microscope. It determines the current location (x and y) of the laser spot in the scanning area.

Synchronously with the detection of a photon, the detector channel number (n) for the current photon is read into the detector channel register. If a polychromator is used in front of the detector, n represents the wavelength range of the detected photon.

The obtained values for t , x , y and n are used to address the histogram memory. Thus, in the memory the distribution of the photons over time, wavelength, and the image coordinates is built up. The result can be interpreted as a set of 16 image stacks for different wavelengths. Each stack contains 64 images for subsequent times after the excitation.

It should be pointed out that the histogramming process does not use any time gating or wavelength scanning. Therefore, the method yields a near perfect counting efficiency and a maximum signal to noise ratio for a given acquisition time. Due to the short dead time of the TCSPC imaging electronics (180 ns) there is virtually no loss of photons for count rates up to a few $10^5/s$ as they are typical for cell imaging.

The data acquisition runs at any desired scanning speed of the microscope. The data acquisition can be repeated as often as necessary to collect enough photons. Due to the synchronisation via the scan clock pulses, the zoom and image rotation functions of the microscope act also automatically on the TCSPC recording and can be used in the usual way.

4. RESULTS

Fig. 3 shows a HEK 293 cell expressing a hybrid protein in which the cyan (CFP) and yellow (YFP) shifted mutants of the green fluorescent protein are linked together by a short amino acid chain. The image was obtained by summing the photons from all time channels of the CFP fluorescence.

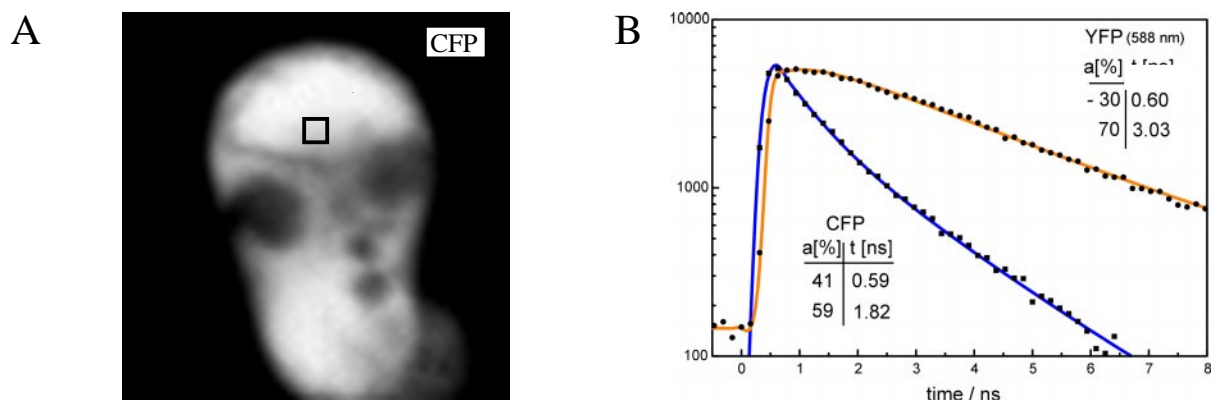

Fig. 3: HEK 293 cell expressing a CFP-YFP hybrid protein

A) Intensity image of CFP. B) Fluorescence decay curves of CFP and YFP in a selected region (square in A).

Fluorescence decay analysis in a selected region (small square) reveals a bi-exponential decay for both, CFP and YFP. The intensity coefficient of the fast component is positive for CFP and negative for YFP, indicating that energy is transferred from CFP to YFP.

While the lifetime of the fast decay component is a measure of the distance between the RET partners the ratio of the intensity coefficients of the decay components is an indicator of the ratio of quenched to unquenched molecules. In Fig. 4 intensity is encoded by the brightness, and the ratio of the coefficients is encoded by the color of a pixel. The results are shown for the CFP and the YFP fluorescence. Due to the fixed link between CFP and YFP, almost no variation is observed in the ratio of the coefficients.

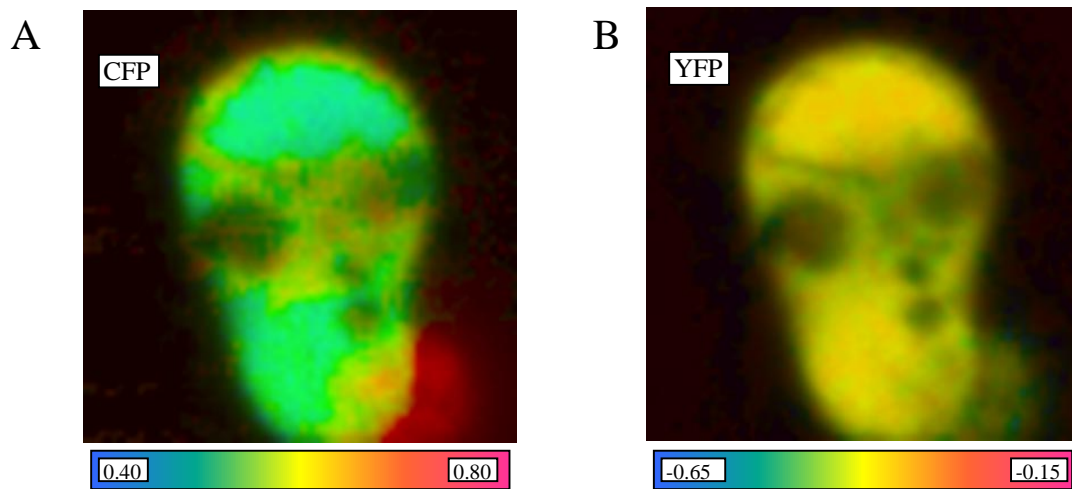

Fig. 4 : RET images for CFP (A) and YFP (B) of a HEK cell expressing a hybrid protein in which CFP and YFP are linked together by a short peptide. Intensity is encoded by the brightness of a pixel. The color is determined by the ratio of the amplitudes of the fast and slow decay components.

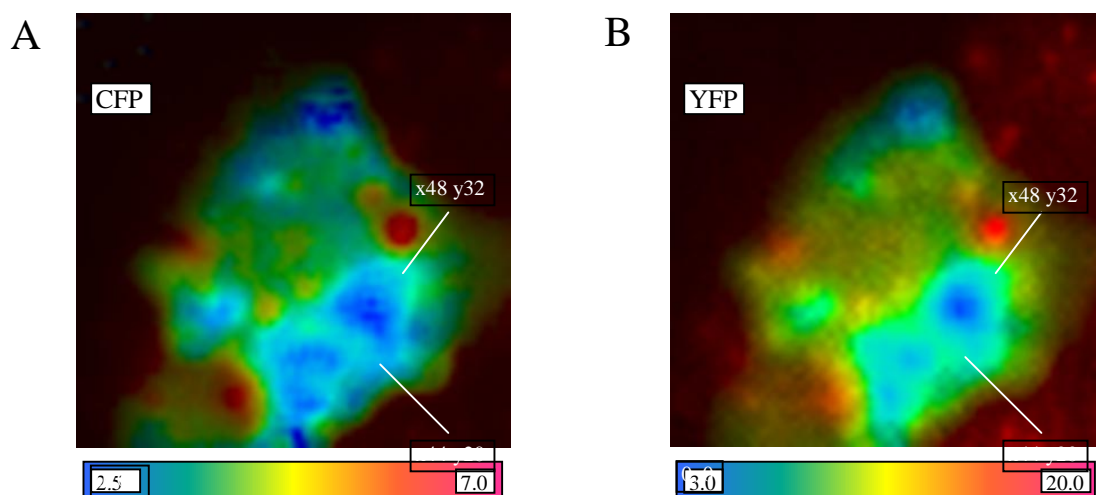

Fig. 5: RET image for CFP (A) and YFP (B) of a HEK293 cell expressing two interacting proteins. Intensity is encoded by the brightness of a pixel. The color is determined by the ratio of the amplitudes of the fast and slow decay components.

Fig. 5 shows RET images of a HEK293 cell, expressing two interacting proteins, which are labeled with a CFP and YFP, respectively. The RET image of the donor (CFP) shows significant variations in the ratio of the amplitudes of the fast and slow decay component. The maximum of this ratio (at x48 y32) coincides with a dark spot in the intensity image of CFP and a bright spot in the intensity image of the acceptor fluorescence. These findings suggest that energy is transferred from CFP (donor) to YFP (acceptor) in this area.

However, the biexponential fit of the fluorescence decay in the wavelength range of the acceptor (Fig. 6) does not yield a fast decay component with a negative amplitude. In contrast to this, the fast decay component has a high positive amplitude. This finding might be caused by the spectral overlap of the emission spectrum of CFP and YFP. In this example, the stoichiometry between CFP and YFP is not fixed so that an excess of CFP fluorescence can bias the YFP fluorescence signal considerably.

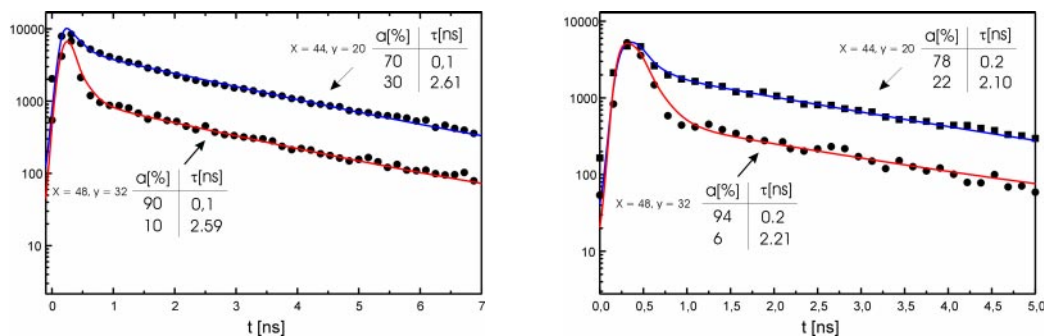

Figure 6: Fluorescence decay curves for CFP (A) and YFP (B) in selected regions of Figure 5.

5. CONCLUSIONS

A new TCSPC imaging technique in conjunction with a laser scanning microscope and a pulsed excitation source yields time- and wavelength resolved fluorescence images. Applied to RET measurements in living cells, the technique delivers the decay components of the donor and acceptor fluorescence in all pixels of the image. The data can be used to create images showing the degree of RET in subcellular structures

6. REFERENCES

1. M. Minsky : Memoir on inventing the confocal microscope. *Scanning* **10**, 128-138 (1988).
2. J.G. White, W.B. Amos, M. Fordham : An evaluation of confocal versus conventional imaging of biological structures by fluorescence light microscopy. *J Cell Biol* **105**, 41-48 (1987).
3. R. Lansford, G. Bearman, S.E.Fraser : Resolution of multiple green fluorescent protein color variants and dyes using two-photon microscopy and imaging spectroscopy. *J. Biomed. Optics* **6**, 311-318 (2001).
4. J.R. Lakowicz, K.W. Berndt : Lifetime-selective fluorescence imaging using an rf phase-sensitive camera. *Rev. Sci. Instrum.* **62**, 1727-1734 (1991).
5. A. Squire, P.J. Vermeer, P.I.H. Bastiens: Multiple frequency fluorescence lifetime imaging microscopy. *J. Microsc.* **197**, 136-149 (2000).
6. E.P. Buurman, R. Sanders, A. Draaijer, H.C. Gerritsen, J.J.F. van Veen, P.M. Houpt, Y.K. Levine : Fluorescence lifetime imaging using a confocal laser scanning microscope. *Scanning* **14**, 155-159 (1992).
7. J. Sytsma, J.M. Vroom, C.J. de Grauw, H.C. Gerritsen, Time-Gated lifetime imaging and micro-volume spectroscopy using two-photon excitation. *J. Microsc.* **191**, 39-51.
8. I. Bugiel, K. König, H. Wabnitz, Investigations of cells by fluorescence laser scanning microscopy with subnanosecond resolution. *Lasers in the Life Sciences* **3**, 47-53 (1989).
9. D.W. Piston, D.R. Sandison, W.W. Webb : Time-resolved fluorescence imaging and background rejection by two-photon excitation in laser scanning microscopy. *SPIE Proc.* 1640, 379-389 (1992).
10. P.T.C. So, T. French, W.M.Yu, K.M. Berland, C.Y. Dong, E. Gratton, Time-resolved fluorescence microscopy using two-photon excitation. *Bioimaging*, **3**, 49-63 (1995).
11. W. Becker, A. Bergmann, K. Koenig, U. Tirlapur, Picosecond fluorescence lifetime microscopy by TCSPC imaging. *Proc. SPIE* **4262**, 414-419 (2001).
12. Becker & Hickl GmbH, SPC-300 through SPC-730 operating manual. www.becker-hickl.de.

13. W. Becker, A. Bergmann, H. Wabnitz, D. Grosenick, A. Liebert, High count rate multichannel TCSPC for optical tomography. Proc. SPIE **4431**, 249-254 (2001).
14. Becker & Hickl GmbH, PML-16 operating manual. www.becker-hickl.de.

Author Information:

Wolfgang Becker
www.becker-hickl.de
becker@becker-hickl.de

Axel Bergmann
www.becker-hickl.de
bergmann@becker-hickl.de

Christoph Biskup
www.mti.uni-jen.de
cbis@mti-n.uni-jena.de